



---

# QUICK-START INSTALLATION MANUAL

FOR USE WITH:

## EAGLE CLAW™ MOUNTING SYSTEM

- SAVE INSTALLATION TIME AND AVOID CALL-BACKS•
- READ THIS MANUAL BEFORE MOUNTING COLLECTORS•

---

### MANUAL CONTENTS

This manual provides a detailed step-by-step procedure for the installation of an Aquatherm Industries Solar Pool Heating System. If the directions are followed correctly and only recommended Aquatherm Industries hardware and components are used, the installed system should provide years of trouble free service, savings, and enjoyment.

**CAUTION:** SOLAR COLLECTORS ARE OFTEN INSTALLED ON THE ROOFS OF BUILDINGS. UNLESS YOU ARE VERY FAMILIAR WITH WORKING ON ROOFS AND HAVE THE PROPER LADDERS AND SAFETY EQUIPMENT FOR SUCH WORK, YOU SHOULD HIRE SOMEONE WITH THE NECESSARY EXPERIENCE TO DO THE INSTALLATION. FAILURE TO OBSERVE SAFE PRACTICES ON A ROOF OR OTHER ELEVATED STRUCTURE MAY RESULT IN FALLING, LEADING TO SERIOUS INJURY TO YOU.

# Product Guide

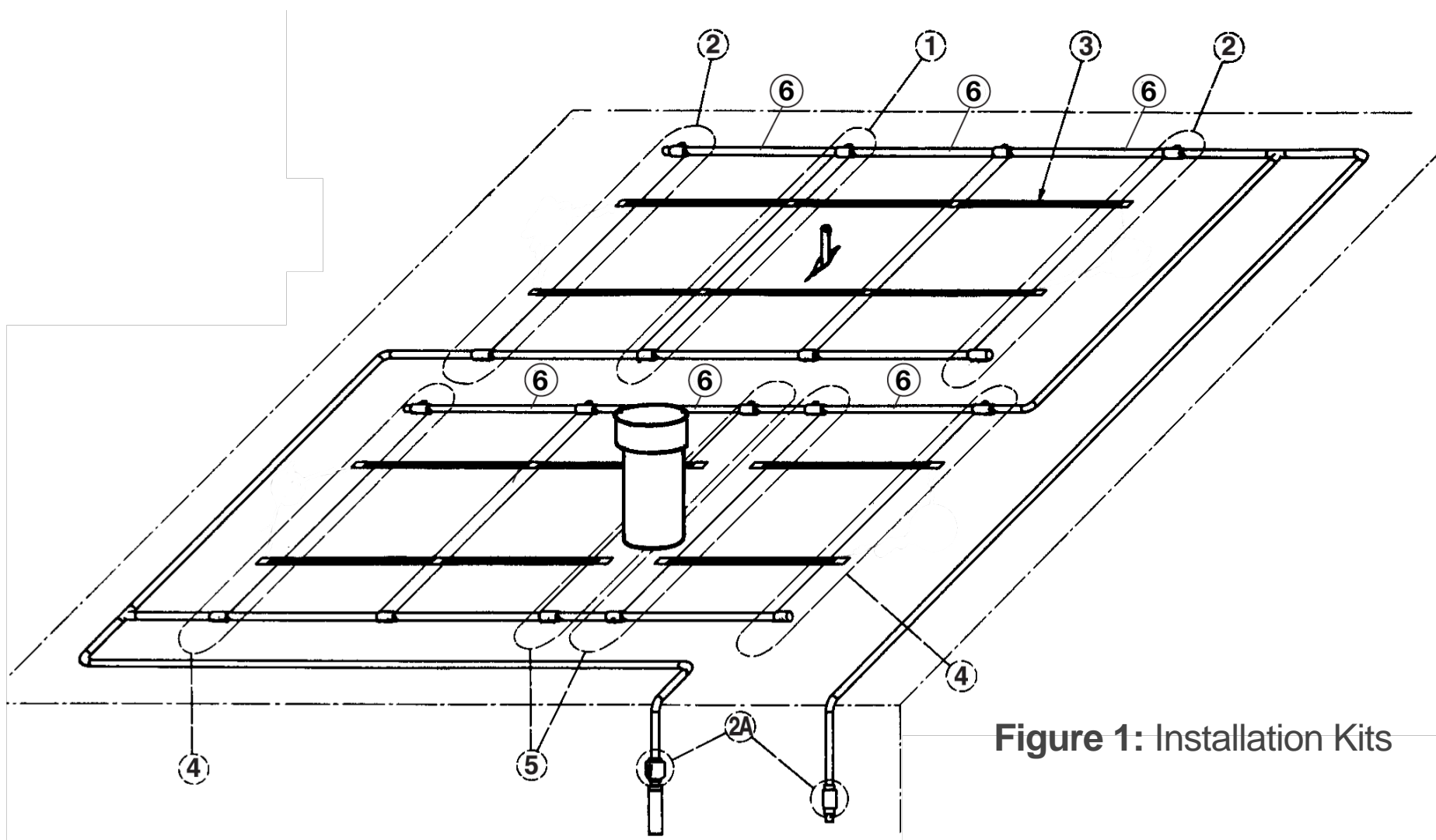

Figure 1: Installation Kits

- 1 Collector Installation Kit**  
 (PN 12034-1 for 1½"; PN 12034-2 for 2")  
 Contains the parts needed to fasten a single solar collector to a supporting surface and make water connections from one collector to another. *Hold-Down Strap* is not included and must be ordered separately. **One (1) kit required per collector.**
- 2 System Installation Kit**  
 (PN 12135-1 for 1½"; PN 12135-2 for 2")  
 Includes additional hold-down hardware, connector hoses, and adapters needed to complete water connections from collectors to the system feed and return line. **One (1) kit required per system.**
- 2A Optional Supplemental System Isolation Kit**  
 (PN 12033-5) - Permits manual isolation of the solar system from the pool or spa filtration system. Includes two (2) 1½" - 2" PVC union ball valves. **Use (1) kit per system.**
- 3 Hold-Down Strap**  
 Required to secure collectors to the mounting surface. Use 54' roll (PN 10035-1) for rows of up to six (6) collectors with two straps. Also available in 107' roll (PN 10035-1) for rows up to twelve (12) collectors with two straps, and bulk 1400' roll (PN 10040).

- 4 Row Kit**  
 (PN 12043-1 for 1½"; PN 12043-2 for 2")  
 Used when more than one row of collectors is to be installed. The kit contains additional hold-down hardware, connector hoses, and adapters. **Use one (1) kit for each row of collectors after the first.**
- 5 Row Spacer Kit**  
 (PN 12017-1 for 1½"; PN 12017-2 for 2")  
 Contains the hardware needed to space around any width obstruction by connecting appropriate lengths of PVC pipe to the *Pipe Adapters* at the inlet and outlet headers of the two collectors on either side of the obstructions. **Use one (1) for each gap between collectors.**
- 6 Supplemental Outlet Header Clamp Assemblies**  
 Used as supplemental outlet header mounting **in conjunction with the Outlet Header Hold-Down Bracket Assembly**. Designed for installations that require more flexibility for the outlet header mounting hardware location, such as barrel tile roofs or installations that require additional mounting hardware to be anchored into rafters or beams.. **Use up to two (2) per collector.**



PN 10117-1 / -2



PN 10121

# Product Guide

## Connections & Hardware



**Outlet Header Hold-Down Bracket Assembly**  
(PN 10008-1, -2)



**Flashing Base, Outlet Header**  
(PN 30340-1)



**Hold-Down Strap Bracket**  
(PN 50006)



**Flashing Base, Strap Bracket**  
(PN 30340-2)



**Double Hole Outlet Header Bracket**  
(PN 50069)



**Hold-Down Strap Clamp Assembly**  
(PN 10011)



**Stainless Steel Hose Clamp**  
(PN 60003-1, -2)



**End Cap**  
(PN 30061-1, -2)



**Vacuum-Relief Valve**  
(PN 10003-1, -2)



**Collector Connector Hose (3 3/4" long)**  
(PN 60690-1, -2)



**System Connector Hose (7" long)**  
(PN 60691-1, -2)



**Pipe Adapter (High-temperature CPVC)**  
(PN 30089-1, -2)



**Check Valve**  
(PN 60019-2)

		Collector Installation Kit (PN 12034-1 / -2)		System Installation Kit (PN 12135-1, -2)		Row Spacer Kit (PN 12017-1, -2)		Row Kit (PN 12043-1, -2)	
		1½"	2"	1½"	2"	1½"	2"	1½"	2"
10008-1, -2	Outlet Header Hold-Down Bracket Assembly	1	1	1	1	1	1	1	1
30340-1	Flashing Base, Outlet Header	1	1	1	1	1	1	1	1
50006	Hold-Down Strap Bracket	2	2	2	2	2	2	2	2
30340-2	Flashing Base, Strap Bracket	2	2	-	-	-	-	-	-
10011	Hold-Down Strap Clamp Assembly	-	-	4	4	4	4	4	4
60003-1, -2	Hose Clamp, Stainless Steel	4	4	4	4	4	4	4	4
30061-1, -2	End Cap	-	-	1	1	-	-	1	1
10003-1, -2	Vacuum Relief Valve	-	-	1	1	-	-	1	1
60690-1, -2	Collector Connector Hose (3 3/4" long)	2	2	-	-	2	2	-	-
60691-1, -2	System Connector Hose (7" long)	-	-	2	2	-	-	2	2
30089-1, -2	Pipe Adapter (high-temperature CPVC)	-	-	2	2	4	4	2	2
60019-2	Check Valve (1½" & 2")	-	-	2	2	-	-	-	-
19001	Installation Manual	-	-	1	1	-	-	-	-
19697	Owner's Manual	-	-	1	1	-	-	-	-

# Figure 2: System Schematic

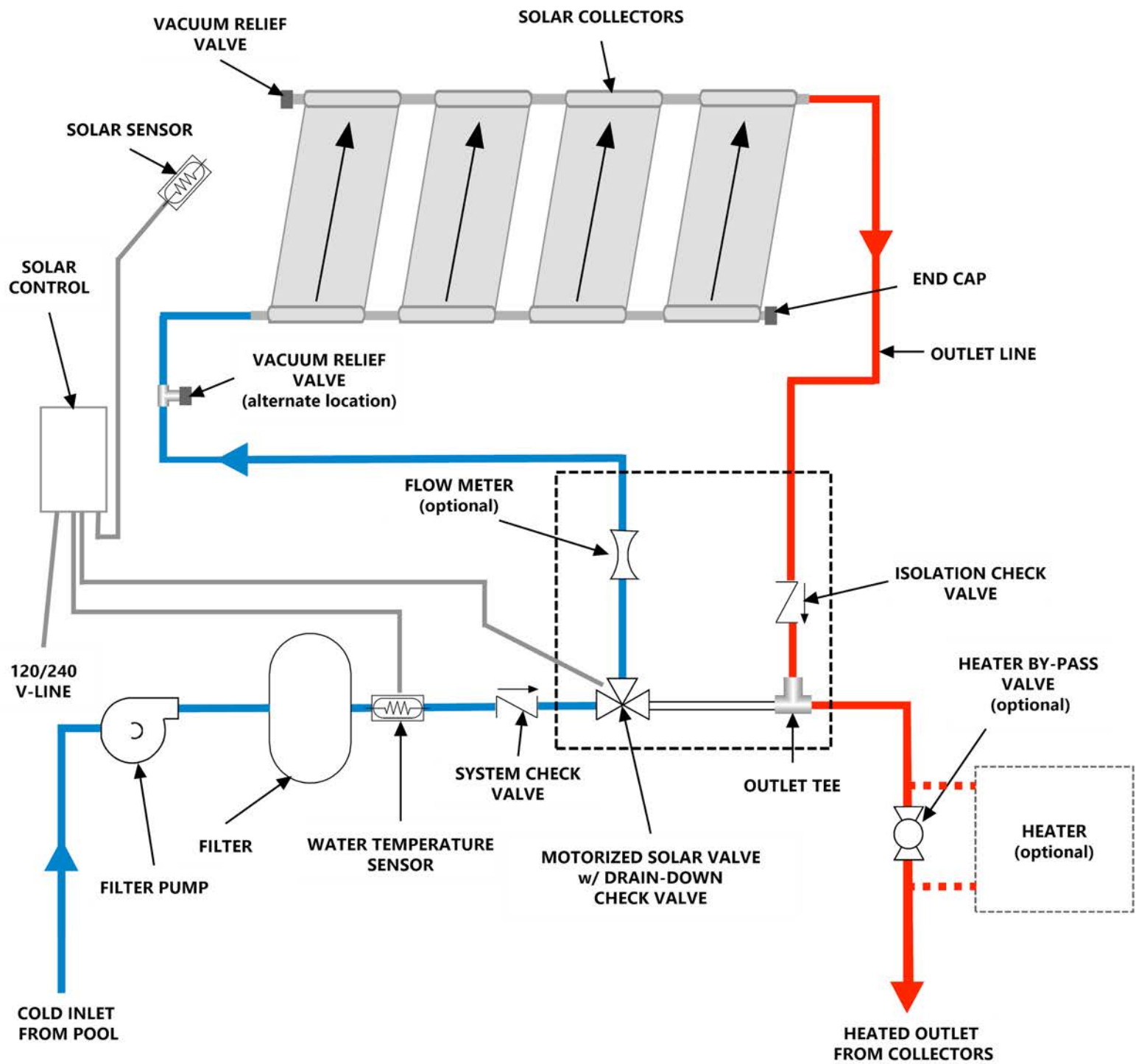
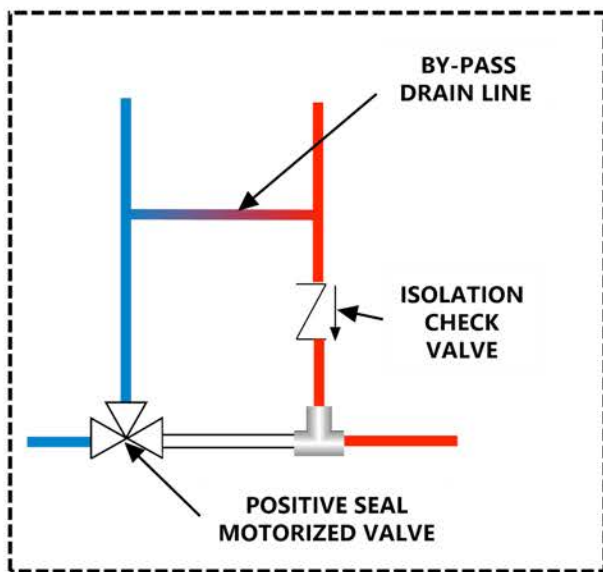
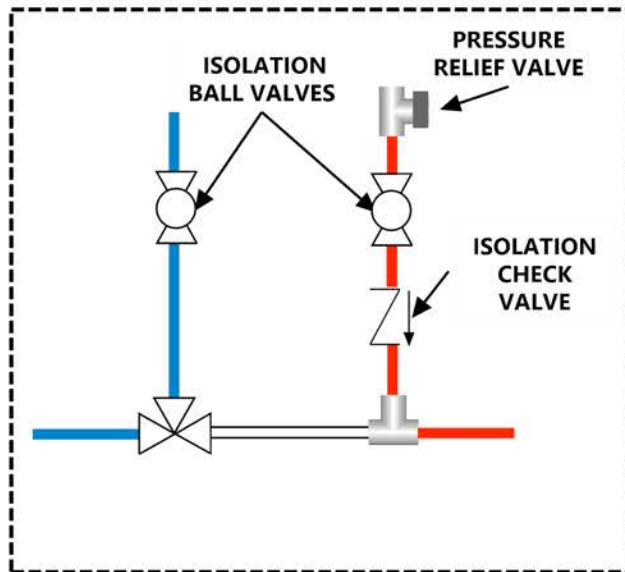

Figure 2A



POSITIVE SEAL w/ BY-PASS DRAIN LINE

Figure 2B



ISOLATION BALL VALVES w/ PRESSURE RELIEF



# Mounting the Collectors

## Collector Layout Overview & Planning for Obstructions



### Overview

- When mounting the collectors, always make provisions for inlet connections at the bottom header and outlet connections at the top.
- The outlet headers must be pitched a vertical distance of at least 1/8" per foot (1cm per m) above the inlet headers to assure uniform flow and proper drainage to prevent freezing.
- Plan system location to allow at least 12" (30cm) on all sides of the row(s) of collectors for mounting brackets and piping.

**Roof obstructions**, if present, should now be taken into account to determine the exact collector location.

Collectors can be installed over or around different diameter roof vent pipes or other obstructions. After snapping the top chalk lines but before marking and pre-drilling for your outlet header brackets, refer to the following instructions:

**For roof vents up to 2" (50mm)** in diameter the collectors can be installed directly over these vents. Locate the seam in the panel nearest to where the vent pipe is to come through. Separate by pulling up on top plate, and pushing down on the lower plate. Should the vent pipe protrude near a sonic tack weld, it will have to be cut apart. Using a sharp utility knife, cut through the

weld while pulling the two plates apart. Lay the collector over the vent pipe, keeping the vent pipe at least 12 inches (30cm) away from a header. It will be easier to complete an installation by mounting this panel first and then working away from it.

**For obstructions up to 7" (18cm)** in diameter, the collectors can be positioned on either side of the vent. Two 7" (18cm) long *System Connector Hoses* (PN 60691-1 for 1½" or PN 60691-2 for 2") can be employed to couple the collectors together for vent pipes or other obstacles up to 7" (18cm) in diameter. Mark your 51" (128cm) centers wherever the outlet header brackets 'fall' on the upper chalk line.

**For obstructions over 7" (18cm)** in diameter, such as attic fans and skylights, position collectors on either side of the obstruction using a *Row Spacer Kit* (PN 12017-1 for 1½"; PN 12017-2 for 2") or *Header Spacers* (PN 30017-1, 2, 3, 4 for 1½"; 30159-1, 2, 3, 4).



*Using various configurations of hoses and header spacers, this system avoids roof obstructions while maximizing the solar collector area. (Photo courtesy of Solar Living - Fair Lawn, NJ)*

# Mounting the Collectors

## Step 1: Install Outlet Header Hold-Down Bracket Assembly

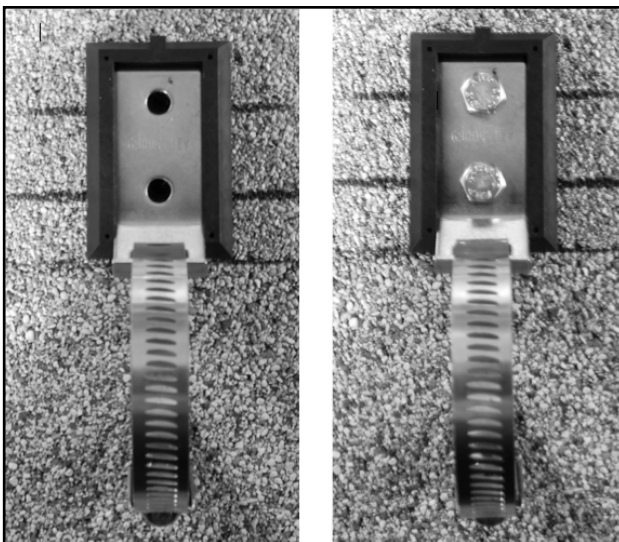

1. Determine the position of the last *Outlet Header Hold-Down Bracket Assembly* for the row of collectors, and mark this point on the roof. The collector outlet headers will be located 1" (25mm) below this mark.
2. Using this point, snap a chalk line to the opposite end of the row. **Slope this line down the roof toward the inlet a minimum of 1/8" per foot (1cm per m).**
3. Using a 1/8" (3mm) drill bit (for 1/4" (6mm) diameter screws), drill a pilot hole for the first *Outlet Header Hold-Down Bracket Assembly* on the first roof mark.
4. Measure up 1" (25mm) on center from the first pilot hole and drill a pilot hole for the second screw. Repeat this process all along the chalk line for the total number of collectors to be installed.
5. Inject a generous amount of high quality sealant into each hole and onto the surrounding roof surface. Attach the *Flashing Base & Outlet Header Hold-Down Bracket Assembly* to the roof as shown in **Figure 3**.

**FIGURE 3**

## Step 2: Hold-Down Strap Bracket Locations

1. Locate the *Hold-Down Strap Bracket* (PN 50006) locations using Table 1 below. Measure "(A) Distance" down from the top *Outlet Header Bracket*, and snap a chalk line to the opposite end of the row. If using the *Optional Supplemental High Wind Area Collector Hold-down Kit*, use (A2) Distance from the outlet header for all three top straps
2. The "(B) Distance" can be measured after the collectors are installed, and is the same for all collector sizes: 16" (40cm) up from the outside of the inlet header.



**Wait to install the Hold-Down Strap Brackets until after collectors are installed, so as not to damage the collectors when you are bringing them to the roof for installation.**

**TABLE 1** DISTANCE BETWEEN COLLECTOR HEADERS AND STRAPS

Collector Panel Size, Feet (m)	12 (3.7)	10 (3.0)	8 (2.4)	6 (1.8)	4 (1.2)
(A) Distance from outside of Outlet Header, Inches (cm)	60 (152)	48 (122)	36 (91)	24 (60)	-
(A2) Distance from outside of Outlet Header, Inches (cm)	32 (81)	28 (71)	20 (51)	-	-
(B) Distance from outside of Inlet Header, Inches (cm)	16 (40)	16 (40)	16 (40)	16 (40)	16 (40)



# Mounting the Collectors

## Step 3: Install Connection Hoses on Collectors



***Make sure that the header with the serial number label is used for the outlet or top header.  
The serial number label must face downwards towards the mounting surface.***

1. Bring the first collector to the roof and slip the proper hoses over both ends of the inlet and outlet headers on the last return collector.
2. Use *System Connector Hoses* (PN 60691-1 for 1½”; PN 60691-2 for 2”), at the system’s feed and return points (outlet of the last collector and the inlet of the first collector).
3. Place a hose clamp between the two indicator ridges on the hose, in order to center it over the sealing groove in the header. This clamp must face up so as to be accessible for tightening and not rub against the mounting surface.
4. Make sure you securely tighten each clamp with a nut driver. If a nut driver is not available, a ‘hex’ wrench or screwdriver will suffice.

**The hose clamps must be located between the two indicator ridges on the hose.**

**Do not tighten more than 35-40 inch-pounds!**

## Step 4: Secure Outlet Header Bracket to Collector Connector Hoses

1. Position the collector on the roof so that the center of the outlet *Connector Hoses* are directly beneath the secured Outlet Header Hold-Down Brackets.
2. Open the clamp that is part of the outlet header bracket, insert connection hose and **lightly tighten** the clamp around the hose.
3. Loosely place another clamp over the open end of the hose before installing the next collector in the array. Refer to **Figure 4**.
4. Continue to install all the collectors in the array, coupling them side to side.

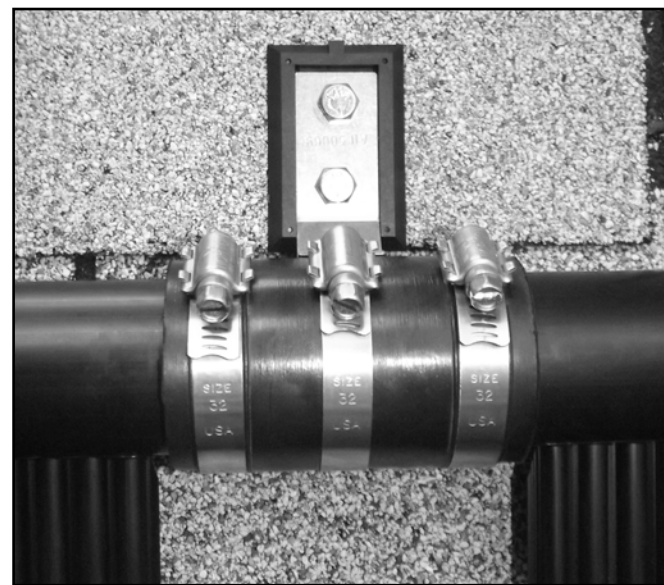

**FIGURE 4**



### Supplemental Mounting Hardware

If using the supplemental *Aluminum Header Clamp Assembly*, (PN 10117-1 for 1½”; PN 10117-2 for 2”), or *GFPP Outlet Header Clamp Assembly*, (PN 10121) install after both the *Outlet Header Hold-Down Brackets* and collectors have been installed.

# Mounting the Collectors

## Step 5: Install Hold-Down Strap Brackets & Stainless Steel Strap

1. At the lower chalk line previously snapped on the roof, mark locations for the first row of *Hold-Down Strap Brackets* 2" (5cm) away from the first and last collectors and centered between each collector.
2. Drill a pilot hole and apply sealant, then mount the *Flashing Base and Hold-Down Strap Bracket*. Slip a *Strap Hold-Down Clamp* (PN 10011) over the end of the strap prior to pulling it through (refer to **Figure 5**).
3. Loop approx. 2" of strap through the *Outlet Header Bracket* and then back through the *Hold-Down Strap Clamp*. Slide the *Hold-Down Strap Clamp* towards the *Hold-Down Strap Bracket*. The screw should be tightened securely, but not over-tightened to the point where the clamp is distorted (refer to **Figure 5**).

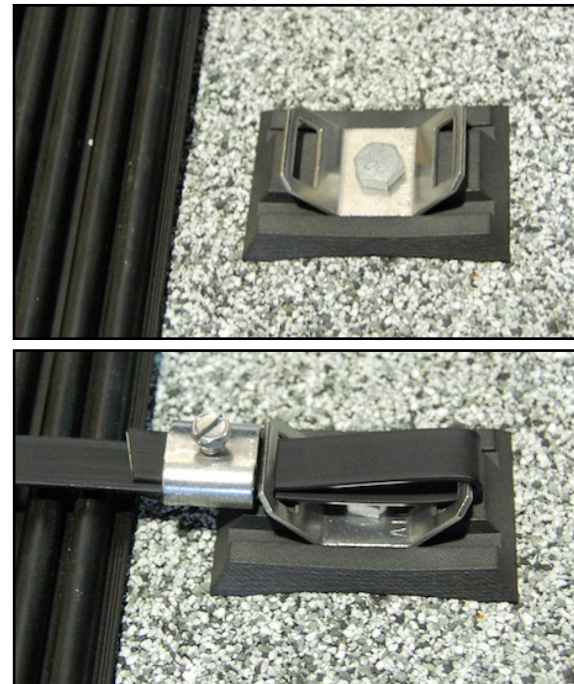
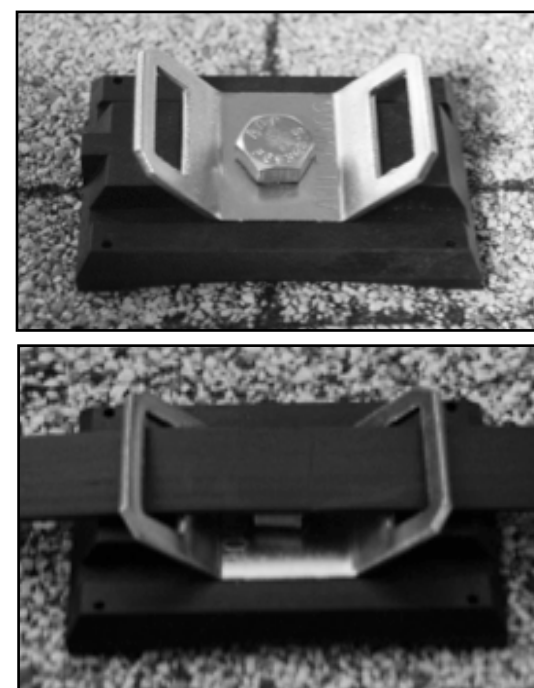

**FIGURE 5**



***For longer arrays it will be easier to start the strap in the middle collectors and work your way out.***

4. Moving across the row, drill pilot holes at each marked point between collectors, apply sealant, and attached all *Flashing Bases and Hold-Down Strap Brackets* to the roof.
5. Bring the remaining strap end across the collector face, passing through both slots of the *Hold-down Strap Brackets* between collectors. Pull strap taut against the face of the collectors. Repeat strap termination at opposite end (refer to **Figure 6**).
6. Mark, drill, and mount the remaining *Hold-Down Strap(s)* by repeating the above steps at the distance(s) specified in **Table 1** in Step 2: Hold-Down Strap Bracket Locations.



**FIGURE 6**



***It is ok to step on the collectors, as long as you stay one foot away from the top and bottom headers.***



# Mounting the Collectors

## Step 6: Install Vacuum Relief Valve & End Cap



1. Install the *Vacuum Relief Valve* (PN 10003-1 for 1½"; PN 10003-2 for 2") in the outlet header of each row.

This will be located at the opposite end of the header that is connected to the collector return line.



2. Install an *End Cap* (PN 30061-1 for 1½"; PN 30061-2 for 2") in the inlet header of each row, opposite the end that is connected to the collector inlet pipe.



**The hose clamps must be located between the two indicator ridges on the hose. Do not tighten more than 35-40 inch-pounds!**

## Installation in High Wind Areas

In regions where high winds are prevalent, use the *Supplemental High Wind Area Collector Installation Kit*, (PN 12035-1 for 1½"; PN 12035-2 for 2") and *Supplemental Row/System Kit* (PN 12143-1 for 1½"; PN 12143-2 for 2") in addition to the standard installation kits (**refer to Figure 7**). The included bracket assembly's spring-tension design allows for collector expansion and contraction, while providing an additional mounting point. *Supplemental High Wind Kits* also contain the required hardware for two additional *Hold-down Straps*. Use **Table 2** below to determine proper spring-tension length, based on collector size and average air temperature.

**FIGURE 7**

**TABLE 2** SPRING TENSION LENGTH

TEMP	8'	10'	12'
0	5"		
15	5"	5"	5"
30	4- 3/4"	4- 3/4"	4- 3/4"
45			4- 3/4"
60			4- 3/4"
77	4- 1/2"	4- 3/4"	4- 3/4"
85		4- 3/4"	
100		4- 1/2"	4- 1/2"
115	4- 3/8"	4- 1/2"	4- 1/2"
130		4- 1/2"	
145		4- 3/8"	4- 3/8"
160	4- 3/8"	4- 3/8"	4- 3/8"

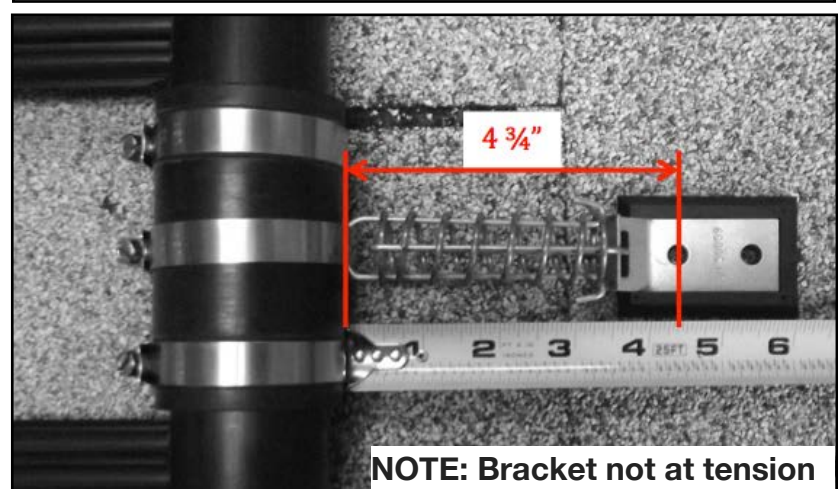
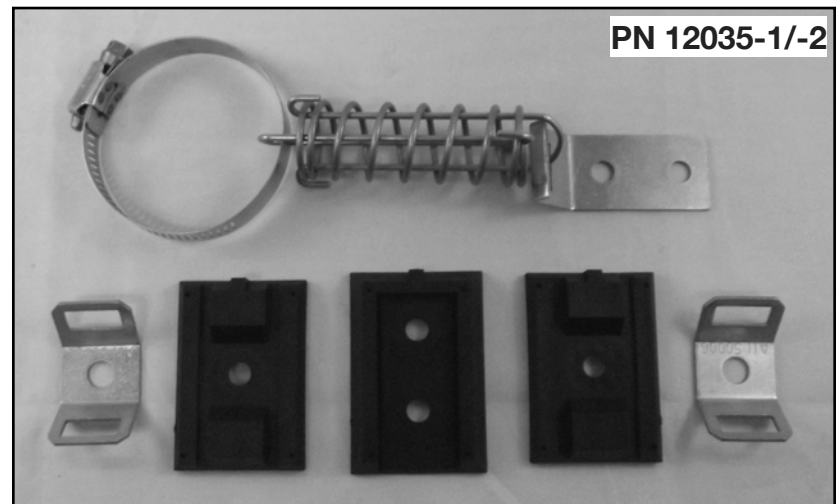

# System Piping

## Overview

Piping to and from the collectors should be the same type of plastic piping and fittings approved for use with swimming pool filters and pumps. It is recommended to always use Schedule 40 PVC pipe and fittings.

Whenever there is more than 50 gpm (189 Lpm) required flow rate to the collectors or more than 100' (30m) of piping used in a system, install 2" (63mm) piping to and from the collectors. See **Table 3** for Pipe Size Based on Flow Rate.

**TABLE 3: PIPE SIZE BY SYSTEM FLOW RATE**

FLOW RATE (GPM)	MINIMUM PIPE SIZE @ 7 FT/S VELOCITY (INCHES)	MINIMUM FLOW TO PURGE AIR			SUPPORT CENTERS FOR HORIZONTAL PVC PIPE (FEET) @100°F	
		FLOW-UP	HORIZONTAL FLOW	DOWN FLOW	SDR&SCH. 40	SCH. 80
		2 FT/S	4 FT/S	6 FT/S		
50	1.5	11	22	33	5.0	5.5
80	2.0	20	39	59	5.0	6.0
115	2.5	31	61	92	5.5	6.5
160	3.0	44	88	132	6.0	7.0
300	4.0	78	157	235	6.5	7.5
650	6.0	176	353	529	7.5	9.0
1050	8.0	300	650	1000	8.0	8.5

- If a fuel-fired heater or heat pump is installed, it should be located between the solar return line and the return line to the pool.
- Although PVC pipe is generally white, black is also available but may be difficult to find locally. If black pipe is desired for aesthetics, it can always be painted black. Before painting, the PVC pipe must be wiped with cleaner to remove the glossy surface coating. This will ensure that the paint will not flake off prematurely.
- Use a PVC cutter or a PVC wide-blade saw (not a hacksaw) for cutting pipe. It is important to use both a quality cleaner/primer and solvent in gluing a PVC joint. Finally, use a cloth while either gluing or painting to keep the job a clean one.
- Piping should also be supported at intervals based on pipe size (see **Table 3**). Aquatherm Industries *Pipe Brackets* made from high-strength glass-reinforced polypropylene are available in 1½" (PN 30272-1 black; PN 30284-1 white) and 2" (PN 30272-2 black; PN 30284-2 white). These may also be used with the two-hole *Flashing Base* (PN 30340-1).



# System Piping

## System Piping Configurations

The most common piping configurations use a pressure filter. The pump draws the water from the skimmer and/or a main drain, forcing it through the filter and sending it back to the pool through the return lines. (For other types please contact Aquatherm's Engineering Department).

FIGURE 8

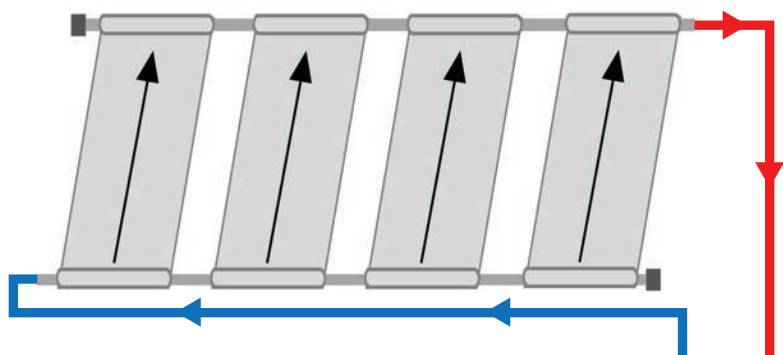

### Reverse Return

In a traditional reverse return piping configuration, the feed and return points of each row of collectors will be diagonally opposite each other (see Figure 8)

The *Vacuum Relief Valve* and *End Cap* of each row will also be diagonally opposite each other.

Using a reverse return configuration ensures balanced flow across the entire row of collectors.

FIGURE 9

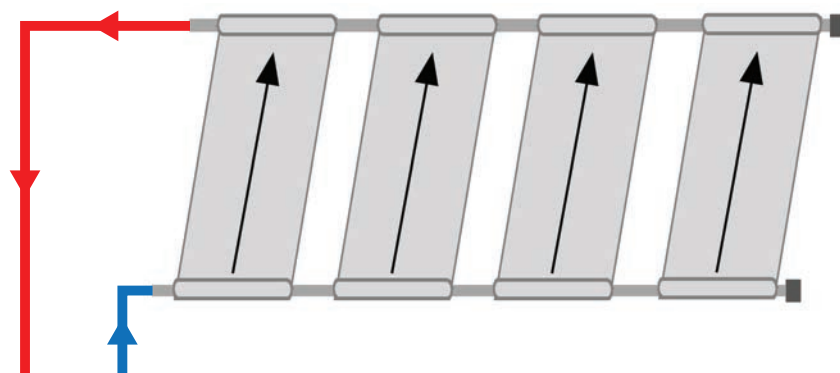

### Direct Return

In certain situations, it may be desirable to configure a system with the feed and return points on the same side of a row of collectors (see Figure 9).

Though this configuration reduces the total pipe required, and is often more aesthetically-pleasing, proper flow rates are crucial to ensure balanced flow through each row.

See **Table 4** below to determine the maximum number of collectors allowable in a direct return system at various flow rates.

TABLE 4: REQUIRED FLOW FOR DIRECT RETURN

COLLECTOR SIZE:	8'		10'		12'	
	1½"	2"	1½"	2"	1½"	2"
MINIMUM FLOW RATE (0.06 GPM/FT <sup>2</sup> )	-	-	-	-	-	-
STANDARD FLOW RATE, (0.10 GPM/FT <sup>2</sup> )	6	6	6	6	6	6
RECOMMENDED FLOW RATE, (0.15 GPM/FT <sup>2</sup> )	7	8	7	8	7	7
MAXIMUM FLOW RATE, (10 GPM PER COLLECTOR)	8	12	8	10	8	8



# System Piping

## Flow Rate

In order to achieve optimum performance from Aquatherm Industries collectors, the recommended flow rates and number of collectors per row in **Table 5** should be followed.

When the system is running, all the collectors should feel uniformly cool to the touch, and there should be no residual air left in the pool return lines. If collectors feel warm or hot to the touch, or air bubbles in the return line persist, chances are that flow through the collectors is inadequate or the system is not properly balanced (refer to the section concerning the **Vacuum Relief Valve Test** on page 14.



- A flow meter can be installed in the collector feed line to check the flow rate. If the flow rates are within the limits as shown above in **Table 5**, the system may not be properly balanced, especially in systems with multiple banks of collectors.

**TABLE 5: FLOW RATES**

COLLECTOR SIZE, FEET:	4 X 12	4 X 10	4 X 8
STANDARD FLOW RATE PER COLLECTOR, GPM (LPM)	5.0 (18.9)	4.0 (15.1)	3.25 (12.5)
MINIMUM FLOW RATE PER COLLECTOR, GPM (LPM)	3.0 (11.4)	2.5 (9.5)	2.5 (9.5)
MAXIMUM # COLLECTORS PER ROW, 1½"; 2"	10; 12	12; 12	12; 14
MAXIMUM SQUARE FOOTAGE PER ARRAY, 1½"; 2"	480; 576	480; 576	480; 576

**PRESSURE DROP (PSI @ GPM):**      1½" - 0.05 @ 2.5; 0.13 @ 5.0; 0.39 @ 10.0  
   2" - 0.05 @ 2.5; 0.20 @ 5.0; 0.60 @ 10.0



***If the flow rate is below the minimum as shown in the table above, then the pool pump size, pump speed, or pipe size should be increased, or a booster pump installed in some cases.***

***If the flow rate is excessive (more than 10 gpm / 37.9 Lpm) collector), or if the system pressure is greater than 30 psi, a By-pass Check-Valve (PN 60717) should be installed between the collector feed and return lines above the 3-way valve to prevent problems with the collectors and connection hoses.***

If the system has been installed according to this manual, optimum performance conditions will now exist. Systems with rows of collectors of unequal size, but fitted with balancing valves, may now be adjusted.

Open all balancing valves completely and let the system run for several minutes. Any row that is warmer to the touch than others is currently receiving less flow than it should for optimum performance. Throttle the valve(s) of the other (cooler) row(s) step-by-step, each time waiting for a few minutes, and check the temperature. Once all rows feel uniformly cool, the system is balanced and operates at optimum performance. Should unexpected problems be encountered, the flow rate must be checked out more thoroughly.

# System Piping

## Optional Isolation Valves

If the system has been installed in accordance with this manual, and a Solar Valve with Drain-down Check Valve (see Figure 2A on page 4), or a Positive Seal Valve with a By-pass Drain Line (see Figure 2B on page 4) has been used, the solar collectors will be isolated and able to drain each time the solar system cycles off and the filtration pump shuts off.

As an added measure of safety, two isolation ball valves may be installed in the collector piping feed and return lines so the pool's filtration system may be operated during freezing weather or for service.

Both valves, available in the *Supplemental System Isolation Kit (PN 12033-5)* are made to accept either 1 ½" pipe or a 2" coupling. Make sure that the ball valves are located close to the diverter valve and outlet tee respectively.

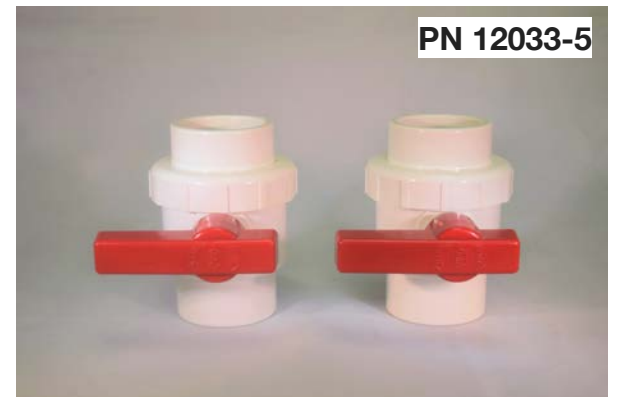

To manually isolate the solar collectors with the Supplemental System Isolation Kit, first turn the filtration pump off and allow 30 minutes for the water to drain out of the collectors and system piping. Then place the solar control into the "Off" or "Pool", or "Solar Disabled" position and turn both isolation valves 90 degrees into the closed position. The filtration pump may then be restarted. When returning the solar collectors to service, first open up the isolation valves and then return the solar control to "Auto", or "Solar Enabled" position.



***If the Supplemental System Isolation Kit is used, it is also recommended to install a 30 psi pressure relief valve in the system piping between the solar collectors and the isolation ball valves. If the system is installed on a commercial or public pool, local codes may require use of the Supplemental System Isolation Kit and pressure relief valve.***

## Control Systems

### Control Types

**Automatic Temperature Control:** The performance of a solar pool heater can be maximized with the use of a solar control and motorized diverter valve. When solar energy is available, the solar control activates the motorized valve, sending water through the collectors for heating (or nocturnal cooling). When the pool reaches the set temperature, or there is insufficient solar energy available, the motorized diverter valve will turn to bypass the solar system. Refer to the manufacturer's instructions included with the solar control you use.

**Manual Temperature Control:** Some systems employ a manually operated valve to divert the flow of water to the solar system, though this may reduce the overall heating capacity of the system. Pool water continuously flows through the solar system when the filtration pump is on, but can be diverted manually if the pool becomes too warm or during extended periods of insufficient solar energy. A manual temperature control system consists of a manually operated diverter valve in place of the motorized diverter valve.

# Checking for Operations

## System Startup, Testing, and Troubleshooting

Each time the solar system cycles on, there are a few things to watch for:

- ✓ Air will initially be purged into the pool. This may last several minutes.
- ✓ The filter pressure will increase slightly and remain elevated when pool water is flowing through the solar system.
- ✓ When the system is running, all the collectors should feel uniformly cool to the touch.

**Vacuum Relief Valve Test:** When the solar system is first turned on, air in the collectors will be expelled into the pool and bubbles will appear. The appearance of bubbles in the pool should stop after a few minutes.

- If, after a few minutes, bubbles continue to be discharged from pool returns, remove the *Vacuum Relief Valve(s)* and replace it with an *End Cap*. If the bubbles discontinue, the issue may be the *Vacuum Relief Valve* location.
- If bubbles continue, reverse the *End Cap* and the *Vacuum Relief Valve* on the collector array to see if this stops the bubbles in the return lines.
- If bubbles continue after reversing the *VRV* and *End Cap*, relocate the *VRV* to a position in the inlet piping at a height of approximately 3/4 of the elevation of the collectors above the pool. **Refer to Figure 2.**

### Flow Rate Test Methods:

1. **Flowmeter:** The preferred system test method is flow rate. This is also the easiest and quickest method. To check flow rate, install a flow meter in the inlet line to the collectors (follow installation instructions provided with the flowmeter).
2. **Touch Method:** With the system running and the sun shining, all collectors of the system should be uniformly cool to the touch, and the system will be operating at optimum performance.
3. **Temperature Rise Method:** An alternate method to test adequate flow is by measuring the temperature rise of pool water through the system. **It is important that the temperature rise through the collectors be kept as low as possible in order to deliver the maximum amount of heat to the pool.** Use two accurate thermometers - one in the pool water or filtration piping prior to the collectors, and one in the system outlet piping - to measure the temperature rise from solar.
  - Before installing, immerse both thermometers in the pool water for several minutes to compare temperature readings. If they are not identical, make a notation of the difference and add or subtract (as appropriate) this difference to or from the reading taken while you are testing.
  - Turn the pump on and move the flow switch to the “Manual ON” position to divert pool water through the collectors. After at least fifteen minutes of flow to collectors, compare the temperature of the pool water with the water flowing through the outlet piping.



On an average sunny day, with the air temperature approximately 70°F (40°C) the water leaving the collectors should be 1° to 7°F (1° to 4°C) higher than that in the pool. If the water rise is greater than this, insufficient water is flowing through the collectors. This may be caused by a clogged filter, undersized piping, too many elbows in the piping or an inadequate pump.



# Maintenance

## Pool Service & Maintenance

**Backwashing & Adding DE:** It is advisable to bypass the solar collectors when either backwashing your filter or adding Diatomaceous Earth (DE). This prevents the possibility of any DE or other debris from passing through the solar system as well as any other pool equipment downstream of the filter. When the backwashing cycle and/or the adding of DE is complete, run the filtration system for 10-15 minutes before returning your solar heating system to operation.

**Automatic Pool Cleaning Systems:** If you have an automatic pool cleaning system with its own pump, there may be several precautions that you need to take depending on what type of system you have. These precautions prevent the air that is initially purged from the solar system from possibly damaging pool cleaning equipment during the turning on cycle of your solar system.

- **Manual Temperature Control:** Do not start the flow of water through the solar collectors while the pool cleaning pump is running. Allow the air to be purged from the system and then activate your pool cleaning system.
- **Automatic Temperature Control:** If your solar control is not equipped with a timed pool cleaner delay cycle, it will be necessary to run your pool cleaner in the early morning and turn it off before your solar system comes on; or turn it on in the late morning, well after your solar system normally cycles on. If you manually vacuum your pool, bypassing the solar collectors at this time will provide you with full power for better vacuuming performance.

## Cold Weather Operation

In some areas, pool owners operate their pools throughout the winter although light freezing conditions may occur. When solar heaters are operated under these conditions, anti-freeze precautions should be taken, in order to protect collectors and components against unusual or severe freezing conditions. One of the following three procedures should be followed when freezing weather is imminent:

1. If the system has been installed in accordance with this manual, and a Solar Valve with Drain-down Check Valve (Figure 2A) or a Positive Seal Valve with a By-pass Drain Line (Figure 2B) has been used, the solar collectors will be isolated and able to drain each time the solar system cycles off and the filtration pump shuts off. Turn the filtration pump off and allow 30 minutes for the water to drain out of the collectors and system piping. The system will return to normal operation automatically after freezing conditions have passed.
2. If isolation valves have been installed, turn the filter pump off and allow 30 minutes for the water to drain out of the solar collectors and system piping. Close isolation valve(s) if applicable. Switch the solar control to "OFF" or "Solar Disabled". The pool filtering system may then be turned back on. When freezing conditions have passed, open isolation valves and switch the solar control to "AUTO" or "Solar Enabled".
3. If the system cannot be drained and isolated, the accepted procedure for avoiding freezing of the pool piping and filtration system has been to continuously circulate the water. Switch the solar control to the "Manual ON" position so that water circulates through the collectors. When freezing conditions have passed, switch the solar control to "AUTO" or "Solar Enabled". **This method is not recommended where temperatures may drop severely.**

## Winterization Procedures

During normal operation, when the diverter valve is in the "bypass collector" position, all water in the collectors should drain back through the Solar Valve with Drain-down Check Valve or a Positive Seal Valve with a By-pass Drain Line when the filter pump shuts off. If there are isolation ball valves in the collector piping feed and return lines, they should only be closed after the collectors have drained fully. Provided collectors are drained, there are no further requirements for winterizing the solar collectors. The pool piping should be winterized as per your normal practice.

# Troubleshooting Quick Guide

## Performance

Problem:	Check:	Solution:
Weather	<ul style="list-style-type: none"> <li>Cooler / wetter than usual?</li> </ul>	<ul style="list-style-type: none"> <li>Use a cover or blanket</li> </ul>
Low Flow	<ul style="list-style-type: none"> <li>Check for high filter pressure</li> </ul>	<ul style="list-style-type: none"> <li>Clean and/or backwash filter</li> </ul>
Solar Control	<ul style="list-style-type: none"> <li>Power-on indicator light</li> <li>Manual operation</li> <li>Solar &amp; pool sensors w/ Ohm meter</li> <li>Control differential function/setting</li> </ul>	<ul style="list-style-type: none"> <li>Switch / circuit breaker</li> <li>Control / valve / valve wiring issue</li> <li>Replace sensors</li> <li>Adjust temperature differential setting</li> </ul>
Unbalanced Flow	<ul style="list-style-type: none"> <li>Feel collector temperature w/ hand or use infrared thermometer</li> </ul>	<ul style="list-style-type: none"> <li>Plumb to balance</li> </ul>

## Air in Lines

Problem:	Check:	Solution:
Filter	<ul style="list-style-type: none"> <li>Check for high filter pressure</li> </ul>	<ul style="list-style-type: none"> <li>Clean and/or backwash filter.</li> </ul>
Pump Strainer Basket	<ul style="list-style-type: none"> <li>Observe basket for air</li> <li>Other "suction side" leaks</li> </ul>	<ul style="list-style-type: none"> <li>Tighten / replace o-ring or gasket</li> <li>Repair leak</li> </ul>
Partial Flow	<ul style="list-style-type: none"> <li>Check diverter valve</li> <li>Verify flow rate (page 11)</li> </ul>	<ul style="list-style-type: none"> <li>Adjust limit switches (motorized)</li> <li>Increase pump size / speed</li> </ul>
Vacuum Relief Valve	<ul style="list-style-type: none"> <li>VRV sucking air</li> <li>Listen for "chirping" noise</li> </ul>	<ul style="list-style-type: none"> <li>Switch end cap &amp; VRV locations</li> <li>Relocate to collector feed line</li> <li>Use "Heavy Duty" VRV (PN 10127-1/-2)</li> </ul>
Return-line Flow Velocity	<ul style="list-style-type: none"> <li>Verify flow velocity &gt; 6 ft/sec to purge air from piping</li> </ul>	<ul style="list-style-type: none"> <li>Decrease pipe size</li> <li>Increase flow rate</li> </ul>



*For the latest revision of this manual, or to view the complete unabridged manual, please visit [www.aquathermsolar.com/install](http://www.aquathermsolar.com/install)*

**An ISO 9001:2008 Registered Manufacturer**

Aquatherm Industries, Inc.  
1940 Rutgers University Blvd.  
Lakewood, New Jersey 08701

**Phone:** 732-905-9002

**Email:** [info@aquathermsolar.com](mailto:info@aquathermsolar.com)

